

# SD100 Serie

Motor diesel



## ESPECIFICACIONES

Modelo	SD100
Tipo de motor	1 Cilindro, refrigerado por aire, inyección directa.
Diámetro x Carrera	86X72
Cilindrada	420cc
RPM de trabajo	3000
Potencia máxima	10HP (3600RPM)
Arranque	Manual/Eléctrico
Capacidad depósito	5,5L
Consumo	273g/hp-h
Capacidad aceite	1,65L (SAE10W30)
Dimensiones	417X470X494mm
Peso	48K

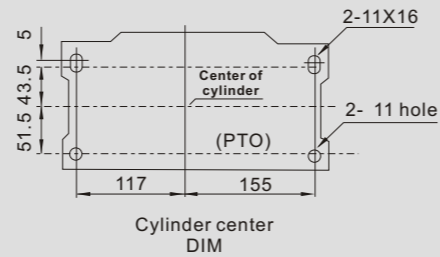
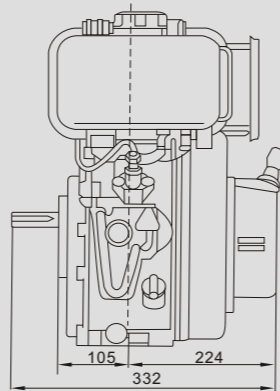
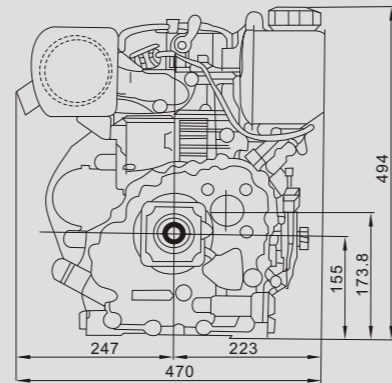

F3(Camshaft POT)

# SD220 Serie

Motor diesel



## ESPECIFICACIONES

Modelo	SD220
Tipo de motor	2 Cilindros en V, refrigerado por aire, inyección directa.
Diámetro x Carrera	86X72
Cilindrada	836cc
RPM de trabajo	3000
Potencia máxima	22HP (3600RPM)
Arranque	Eléctrico
Capacidad depósito	12L
Consumo	298g/hp-h
Capacidad aceite	1,7L (SAE10W30)
Dimensiones	525X480X562mm
Peso	62K

